

Bulkvervoer
Bulk transport

ATCOMEX ISO 9001
OOO I

AFZETTANK 24,5 M³
REMOVABLE TANK 24,5 M³



Atcomex Company nv

Nijverheidslaan 6
B-8560 Gullegem
Belgium
Tel. 32 56 43 99 20
Fax. 32 56 40 00 56
Email: gullegem@atcomex.be
BTW/TVA BE 0425 920 763
RPR/RPM KORTRIJK

Atrefco nv Atcomex Hamme

Industriepark Zwaarveld 11
B-9220 Hamme
Belgium
Tel. 32 52 49 92 90
Fax. 32 52 47 84 32
Email: hamme@atcomex.be
BTW/TVA BE 0433 655 920
RPR/RPM DENDERMONDE

www.atcomex.be

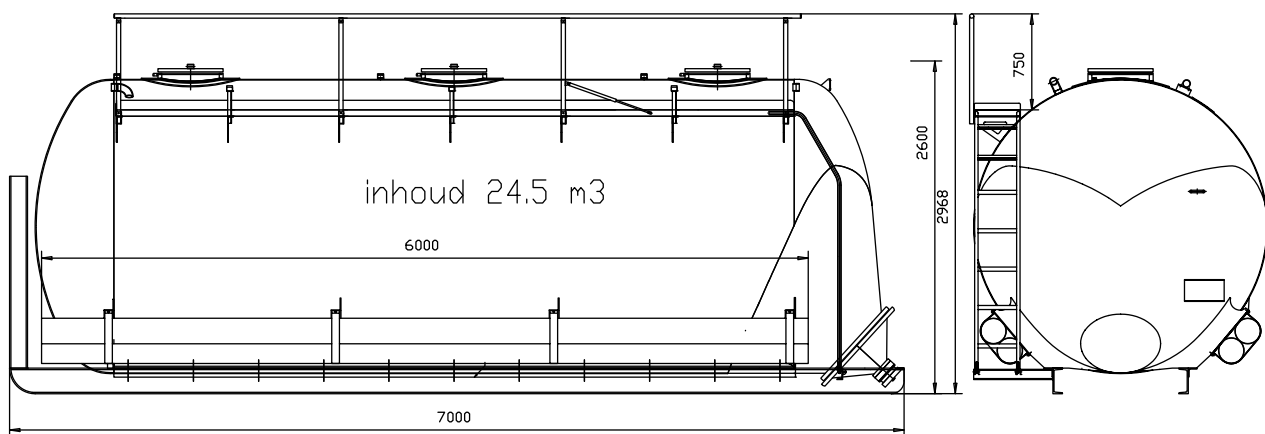

TECHNISCHE SPECIFICATIES

- Type: Afzettank
- Inhoud: 24.5 m³
- Materiaal: ALU
- Lengte: 7000 mm
- Hoogte: 2600 mm
- Breedte: 2300 mm
- Diameter tank: 2300 mm
- Aantal mangatdeksels: 3 (NW450)
- Aantal compartimenten: 1
- Chassis: Staal
- Werkdruk: 2 bar
- Woelbodem NW560
- Manueel bediende reling
- Tank kan in geladen toestand afgezet worden
- PED goedgekeurd

TECHNICAL SPECIFICATIONS

- Type: Removable tank
- Contents: 24.5 m³
- Material: ALU
- Length: 7000 mm
- Height: 2600 mm
- Width: 2300 mm
- Diameter tank: 2300 mm
- Number of manhole covers: 3 (NW450)
- Number of compartments: 1
- Chassis: Steel
- Working pressure: 2 bar
- Straining cloth NW560
- Manual operated railing
- Tank can be removed in loaded condition
- PED approved